

Automated audits simplify compliance for IS732 and CEA regulation

POWEReasy is India's first IOT device that reports high risk electrical faults that the user must fix to avoid fires. It can also be configured to isolate supply for critical faults. POWEReasy protects for 12 fire risks whereas an MCB and RCCB protect for only 3.

POWEReasy comes with a remote command center monitored by electrical experts they analyze & report early warning to prevent critical faults

Smart Optimizer



Live Dashboard with risks analytics

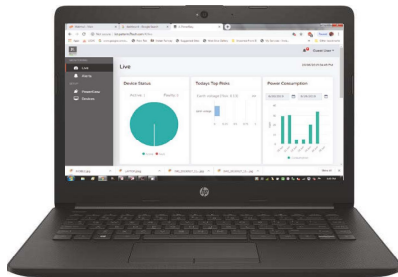

SMS Alerts

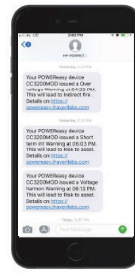

Automated Audits Save lives and assets

Early Warnings Prevent unplanned shutdown

Actionable insights Improves efficiency of electrician

Reports to app Monitoring on the go

Remote Command Center

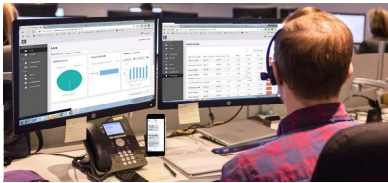

Electrician at Site

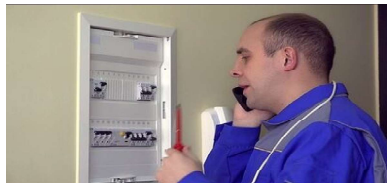

GOVERNMENT REGULATION REQUIRES YOU TO DO AUTOMATED ELECTRICAL AUDIT

DID YOU KNOW ?

Medical Equipments

Bhopal
8 Nov, 2021
Hospital

4 Fatalities

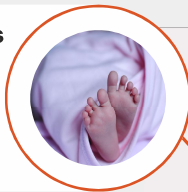

Air Conditioner

Delhi
12 Feb, 2018
Hotel

17 Fatalities

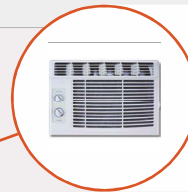

Short Circuit

Ahmednagar
6 Nov, 2021
Hospital

11 Fatalities



Medical Equipments

Bhubaneswar
18 Oct, 2016
Hospital

22 Fatalities



Loose Wiring

Mumbai
4 Jan, 2018
Shop

12 Fatalities

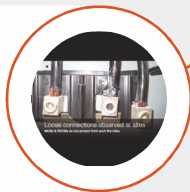

Rodents

Bangalore
28 Dec, 2018
Train

26 Fatalities



65

Fatalities/day due to electrical faults

32:1

Ratio of Fatalities to injuries due to fire

86%

Fire can be prevented by proper maintenance

POWEReasy COMPANY VISION

TO ENSURE EVERY LAST INDIAN GETS RELIABLE ELECTRICITY

POWEReasy automates electrical safety. The patent pending POWEReasy is an IOT enabled device that not only monitors electrical conditions but also identifies all 20 electrical faults. It has the ability to isolate the electrical supply and even diagnose and report issues via the cloud.

- **Automatic, realtime electrical audits.** POWEReasy reports all electrical conditions to a dashboard that is constantly evaluating electrical risks. Electrical audits are no longer an annual event.
- **Fire prevention.** POWEReasy is the only device that can provide early warning and optional isolation covering 12 critical electrical events.
- **Fault Diagnosis with root cause analysis.** POWEReasy command center monitors electrical signatures in realtime to identify 20 unique electrical problems. Our team of experts analyze the root cause, enabling effective and in-time correction to complex electrical faults.

20 KNOWN ELECTRICAL FAULTS

Type of Fault / Functions	Potential Risk from fault				Solution Available	
	Fire	Electro-cution	Damage to equipment	Efficiency loss	MCB + RCCB	POWEReasy
Short circuit	X				Trip	Isolation
Over current	X				Trip	Warning & Optional Isolation
Earth leakage	X	X	X		Trip	Warning & Optional Isolation
Critical Over voltage	X		X		No	Warning & Optional Isolation
Critical Under voltage	X		X		No	Warning & Optional Isolation
Earth voltage	X	X	X		No	Warning & Optional Isolation
Neutral loss	X		X		No	Isolation
Phase/Line loss	X		X		No	Isolation
Arc faults	X		X		No	Optional Isolation
Surge	X		X		No	Protection & Optional Isolation
Current unbalance	X			X	No	Warning
Current harmonics	X		X	X	No	Warning
Phase Reversal			X		No	Optional Isolation
Power factor				X	No	Warning
Voltage harmonics			X		No	Warning & Optional Isolation
Short term interruptions			X		No	Warning
voltage variation			X	X	No	Warning
voltage unbalance			X	X	No	Warning
Inrush current			X		No	Warning
Reverse current		X			No	Warning
Metering					No	Yes

POWEReasy SOLUTIONS SUMMARY

Maximize your performance. Unlock the potential for a new level of electrical safety. "0 downtime", "0 incidence", "lowering near misses", "reducing energy consumption" are just some of the KPIs you can maximize with POWEReasy.

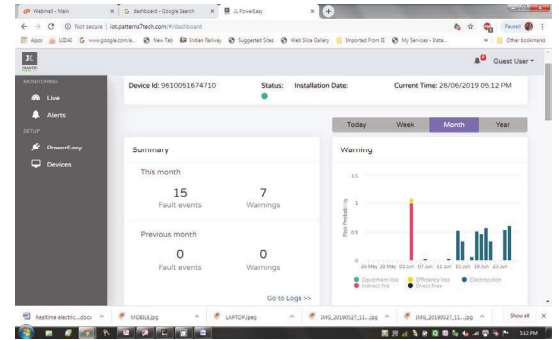

Track & Optimize risks, metrics and KPIs

Type of Product	Smart Optimizer	Smart DB	Smart DB With Optimizer
-----------------	-----------------	----------	-------------------------

POWEReasy range of products



Innovation	5X smaller size Energy saving	Integrated DB with Coverage of all 20 Electrical Faults	Wall Concealed Stabilizer Integrated DB with Energy Saving
Electrical Fire Prevetion	All 12 risks	All 12 risks	All 12 risks
Root Cause Analysis	All 20 risks	All 20 risks	All 20 risks
Surge Protection	Type II	Type II	Type II
SMS & Dashboard	Available	Available	Available
Command Center	Available	Available	Available
Voltage Stabilization	Inbuilt	-	Inbuilt
Energy Savings	With AVO	-	With AVO
Distribution board	-	6Way, 8way, 12way	6Way, 8way, 12way
Mounting	Wall Mounting	Wall Concealed	Wall Concealed

OUR CLIENTS.



POWEReasy INSTALLATION DIAGRAM

Smart Optimizer

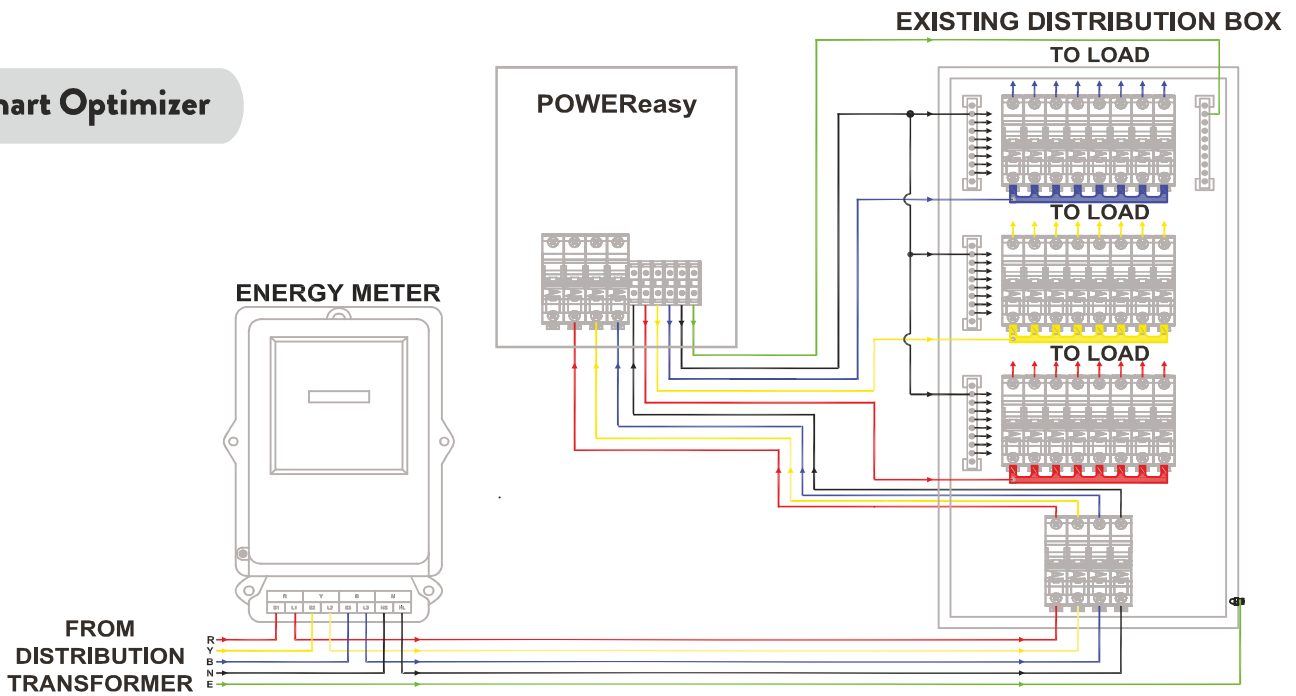

Smart DB with Optimizer

